

# POWER WALKER INVERTER 5000 HYBRID

## INSTALLATION AND OPERATION MANUAL



## SAFETY INSTRUCTIONS



### Risk of Electric Shock

Alternating Current (AC) and Direct Current (DC) sources are connected to this device. To avoid risk of electric shock during maintenance or installation please ensure that all AC and DC connections are disconnected.



### Risk of Electric Shock

When PV module or panel is exposed to light, it starts to supply high DC voltage, be sure to turn off DC switch before commencing the maintenance, and make sure the cables from PV panel are properly sealed after disconnection.



### Risk of Electric Shock

To avoid electric shock resulted from leakage current, make sure the earth cable at AC terminal is well connected before connecting to the utility.



### Risk of Electric Shock

In case there is more than one source of AC/DC power supply, please disconnect all sources before commencing maintenance.



### Risk of Electric Shock

After disconnecting the power sources, the product will continue to discharge at DC terminal for a short period. Before commencing maintenance, please wait for at least 2 minute after the power is disconnected.



**WARNING**  
AUTHORIZED  
PERSONNEL  
ONLY

### Authorized Personnel Only

Only authorized personnel are allowed to install, commission and repair the product.



### Warning

If the product is used in a manner which is not covered by the scope of warranty, the protection provided by the product may be impaired.

## SCOPE OF WARRANTY

The product comes with a standard 1-year warranty. This warranty includes all defects of design, components and manufacturing. The Warranty is void and does not cover any defects or damages caused by in any of the following circumstances:

EN

- Seal on the product is broken
- The product has been misused, neglected, or abused
- Improper transportation and delivery
- The product has been used or stored in conditions outside its electrical or environmental specifications
- The product has been used for purposes other than for which it was designed
- The product has been used outside its stated specifications, operating parameters and application
- Acts of third parties, atmospheric discharges, excess voltage, chemical influences, natural wear and tear and for loss and damage in transit
- Improper testing, operation, maintenance, adjustment, repair, or any modification of any kind not authorized in writing by the supplier
- The product has been connected to other equipment with which it is not compatible
- Use and application beyond the definition in this manual
- Application beyond the scope of applicable safety standards or grid codes
- Acts of nature such as lightning, fire, storm, flood, vandalism and etc.

The right to repair and/or replace the defective product is at the supplier's sole discretion. Any warranty claim shall be asserted in writing to the supplier within 5 working days after notice of product failure. The supplier is not responsible for damages beyond the scope of this warranty.

# Table of Content

<b>1. PRODUCT OVERVIEW .....</b>	<b>5</b>
1.1 PRODUCT OUTLOOK.....	5
1.2 FUNCTION OF MAJOR PARTS .....	5
1.3 SCOPE OF DELIVERY .....	8
1.4 TYPICAL APPLICATIONS .....	9
<b>2. INSTALLATION .....</b>	<b>10</b>
2.1 SAFETY CLEARANCE.....	10
2.2 CONNECTION OF DC INPUT CABLES (FROM SOLAR POWER SYSTEM).....	10
2.3 INSTALL BATTERY BANK.....	12
2.4 CONNECTION OF AC INPUT CABLES (FROM AC GRID OR AC GENERATOR) .....	13
2.5 CONNECTION OF AC OUTPUT CABLES.....	14
2.6 COMMISSIONING.....	15
<b>3. OPERATION .....</b>	<b>16</b>
3.1 OPERATION MODES .....	16
3.2 SOLAR MODE .....	19
3.3 SAVER MODE .....	20
3.4 CONFIGURATION VIA UPPER CONTROL PANEL .....	20
3.5 CONFIGURATION VIA LOWER LCD (SOLAR MODE SETTING) .....	22
3.6 FAULT EVENTS .....	22
<b>4. SPECIFICATION .....</b>	<b>23</b>
<b>5. TROUBLESHOOTING .....</b>	<b>27</b>
<b>6. DISPOSAL .....</b>	<b>30</b>

# 1. PRODUCT OVERVIEW

## 1.1 Product Outlook

EN

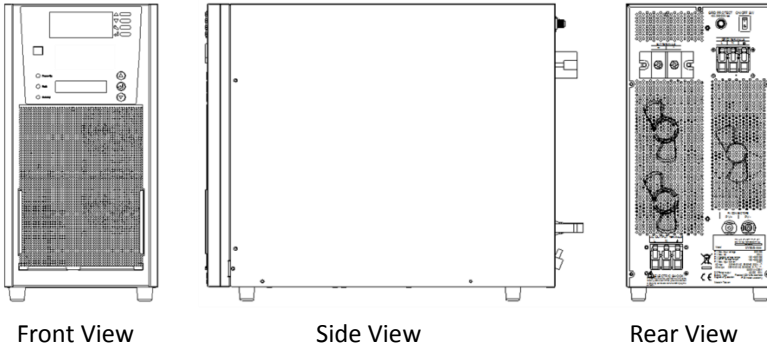

## 1.2 Function of Major Parts

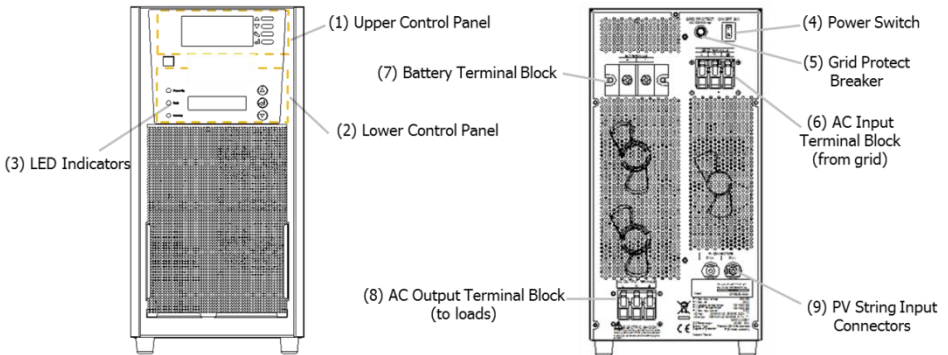

(1) Upper Control Panel: consists of a LCD and function keys allowing the user to operate, configure and monitor the AC inverter and battery charger.

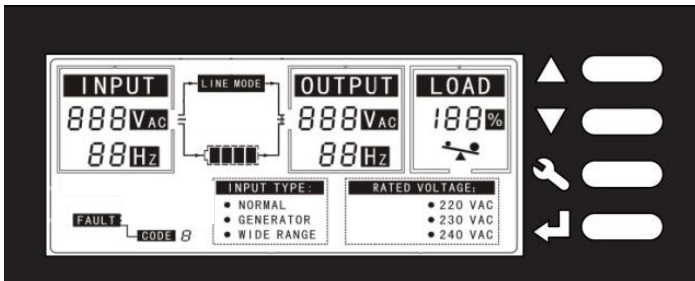

Key	Function	Description
	UP	Move up / Toggle the last item
	DOWN	Move down / Toggle the next item
	CONFIG	Enter configuration mode
	ENTER	Confirm the setting / Enter menu

The LCD indicates the operational status, configuration settings and fault events.

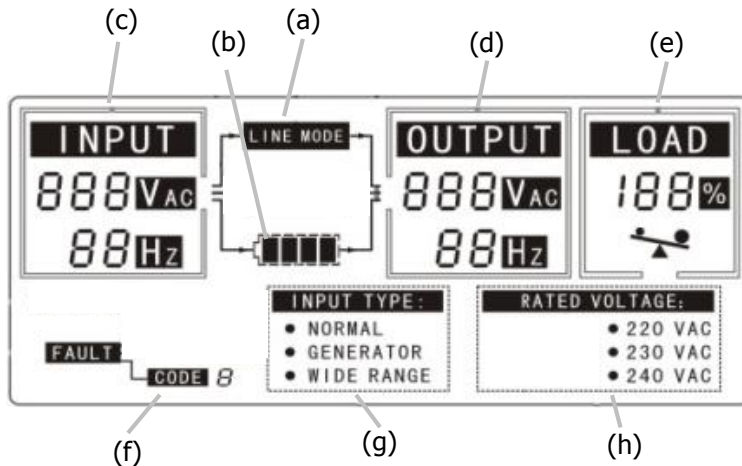



- LINE MODE: when AC input power is present, LINE MODE will be enabled.
- Battery: this symbol indicates the charging status of battery bank under LINE MODE and the remaining battery capacity under INVERTER MODE.
- AC input voltage and frequency
- AC output voltage and frequency
- Percentage of output loading
- Fault indicators which show the fault type and code
- AC Input type setting
- Rated voltage display

(2) Lower Control Panel: consists of a LCD, function keys and LED indicators allowing user to operate, configure and monitor the DC input (PV).

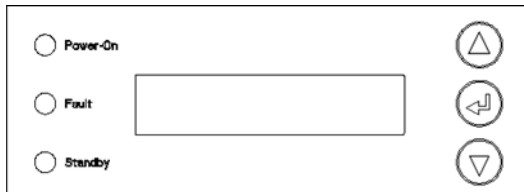
EN



Key	Function	Description
	Up	Move up / Toggle the last item
	Enter	Confirm the setting / Enter menu
	Down	Move down / Toggle the next item

LED	Function	Description
Yellow	Power-On	Power on/off status
Red	Fault	Fault events
Green	Standby	Standby mode ( $V_{DC} < 160V$ )

The lower LCD display the operational status of DC input (PV), and the page can be scrolled with the sequence below by pressing ▲ or ▼ buttons.

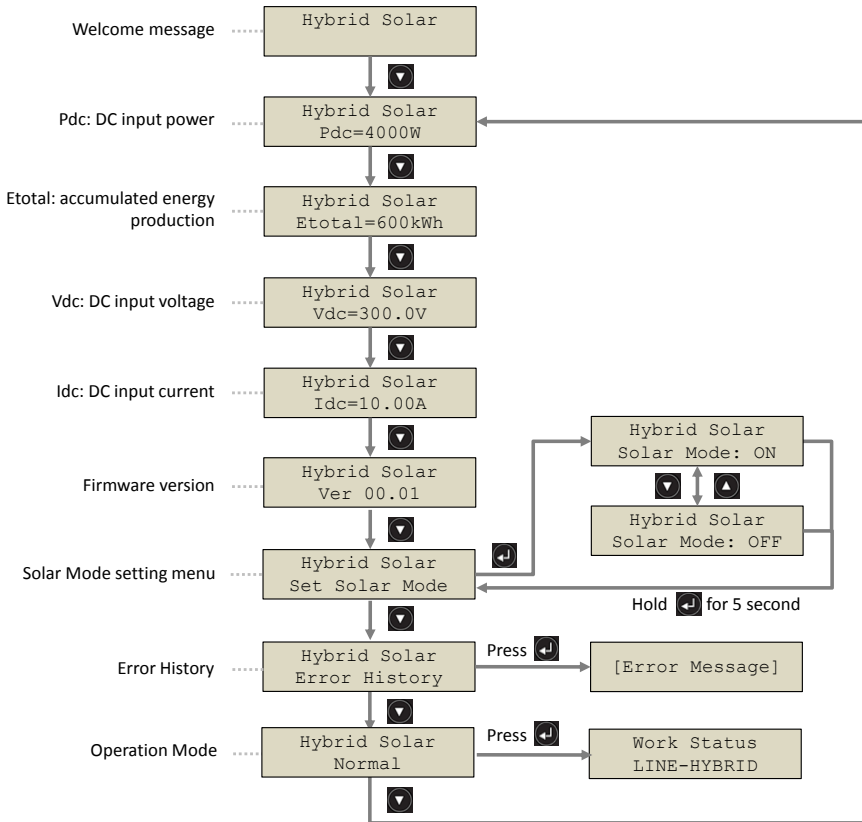

### 1.3 Scope of Delivery

Unpack the carton of POWERWALKER INVERTER 5000 HYBRID and the following items should be included in the carton.

Description	Quantity
POWERWALKER INVERTER 5000 HYBRID	1
DC Cable (Red)	1
DC Cable (Black)	1
AC Terminal Block Cover	2
User Manual	1



## 1.4 Typical Applications

POWERWALKER INVERTER 5000 HYBRID is designed to serve as a backup power supply for AC loads. The input power of POWERWALKER INVERTER 5000 HYBRID comes from PV system and AC grid which not only supply power to AC loads but also charge the battery bank when the power from AC grid or AC generator is present (also known as Line Mode).

EN

In the event of AC grid (or AC generator) outage, the AC loads can be alternatively powered by PV system (if the illumination is sufficient) and battery bank. Please find below the system diagram of typical application.

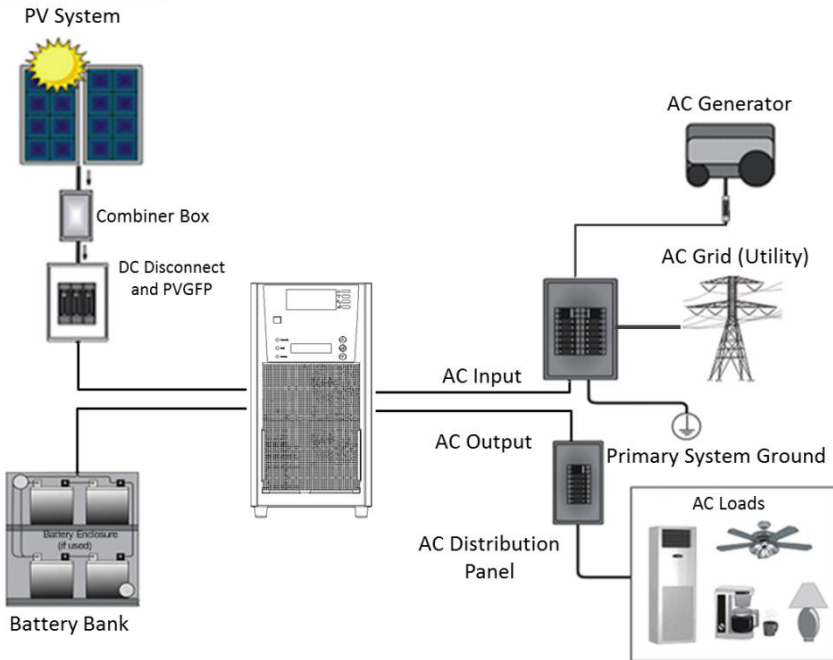

Typical Application of POWERWALKER INVERTER 5000 HYBRID

## 2. INSTALLATION

### 2.1 Safety Clearance

EN

- The minimum clearance to the wall shall be 20cm in order to ensure proper ventilation.
- Please do not place any device on top of POWERWALKER INVERTER 5000 HYBRID.
- For environment with high ambient temperature, increase the clearance to ensure normal operation if necessary.

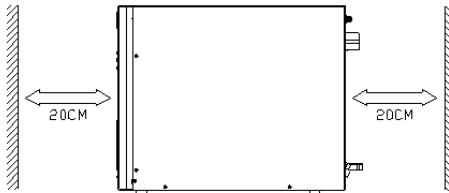

Minimum clearance



#### WARNING!

Before performing the installation, please make sure the power switch is at OFF position and all the cables to be connected to POWERWALKER INVERTER 5000 HYBRID are without electricity.



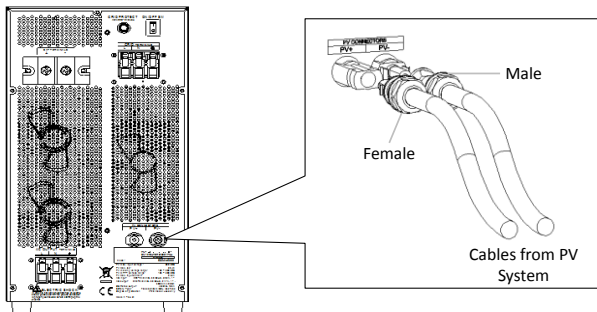

### 2.2 Connection of DC Input Cables (from solar power system)

The two cables from PV system (one positive terminal and one negative terminal) shall be fitted with MC4 plug connectors, so as to connect with POWERWALKER INVERTER 5000 HYBRID as shown in the diagram below.



Connection of DC Input Cables

The DC connectors on POWERWALKER INVERTER 5000 HYBRID are either **Wieland PST40i1** or **Multicontact MC4** DC connectors. The DC connector used for the cables from PV arrays shall be of the same brand in order to ensure reliable connection. The two types of DC connector may be distinguished by the appearance as shown in the table below:

	MultiContact MC4	Wieland PST40i1
Male	 PV-ADSP4	 PST40i1 (Part No: 96.112.1053.1) (Part No: 05.545.2202.8)
Female	 PV-ADBP4	 PST40i1 (Part No: 96.111.1053.1) (Part No: 02.125.8202.8)



### WARNING!

Using DC connector of different brand as one pair might result in poor conductivity, poor insulation or even the damage of DC connectors. The DC cable may also fall off easily and result in the risk of electric shock.

Before fitting the DC connectors on the cables of PV string, it's important to conduct polarity check by following the steps below,

Using multi-meter to measure the PV string's cable ends and check the parity

The positive (+) end of cable shall be fitted with **Female Connector**

The negative (-) end of cable shall be fitted with **Male Connector**

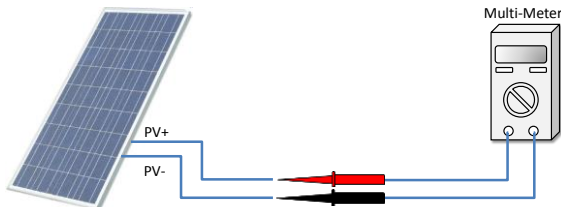

## 2.3 Install Battery Bank

### Battery Bank Configuration

EN

The battery bank shall consist of single type of battery of either flooded lead-acid, or sealed GEL/AGM lead-acid battery. The battery bank shall be configured properly so that the terminal voltage meets POWERWALKER INVERTER 5000 HYBRID's specification, and the total capacity shall be no less than 100AH.

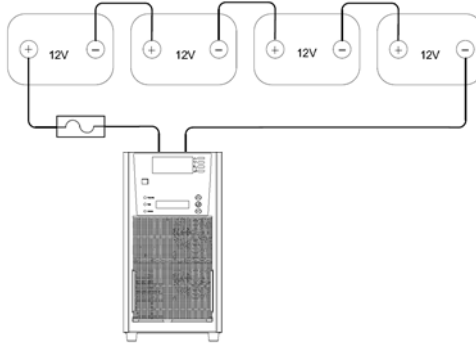

Example of battery bank configuration

### Battery Cable Size and Connection

The recommended cable size for battery bank is **4 AWG** with 1~3 meter cable length. The end of the cable shall be fitted with ring terminals and fix by screws with 30kgf-cm torque. Please check the polarity of battery cables before connection.

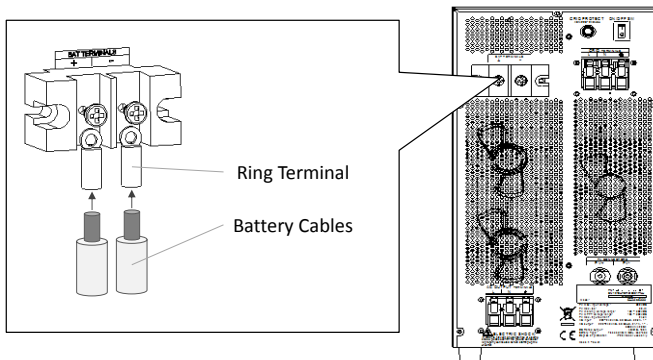

Connection of Battery Cable

**WARNING!**

Installation must be performed with care for the high battery voltage in series. Do NOT place anything between battery cable ring terminals and terminals on the product. The terminal screw is not designed to carry current.

**Disconnect and Over-Current Protection**

Battery over-current protection and disconnect devices shall be installed as per the request of local regulation. Fuses and disconnects must be sized based on the DC rating.

Switching off the power switch of POWERWALKER INVERTER 5000 HYBRID does not constitute the disconnection of battery bank.

## 2.4 Connection of AC Input Cables (from AC grid or AC generator)

The AC input terminal block shall be connected with the cables from AC power source such as AC grid (utility) or AC generator. The recommended cable size is **10 AWG**. To ensure proper connection, the cables shall be fitted with core end terminals with stripped length of 9~10mm and fix to the terminal block with 8kgf-cm torque.

**WARNING!**

As per the requirement of National Electrical Code, an external disconnect switch shall be installed on AC cables before connecting to the product.

Before connecting the AC cables, please make sure the AC voltage and frequency of AC power source fall within the permitted range as set out in the specification.

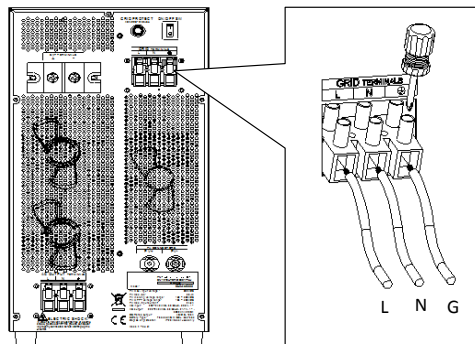

Connection of AC Input Cables

## 2.5 Connection of AC Output Cables

The AC output terminal block shall be connected to the AC loads. The recommended cable size is **10 AWG**. To ensure proper connection, the cables shall be fitted with core end terminals with stripped length of 9~10mm and fix to the terminal block with 8kgf-cm torque.

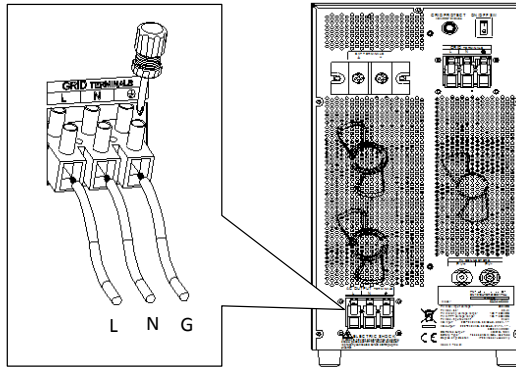

Connection of AC Output Cables



### WARNING!

The AC output terminal of POWERWALKER INVERTER 5000 HYBRID is not designed to feed power into AC grid. Do NOT connect the AC output terminal block to AC grid or any AC power source.

POWERWALKER INVERTER 5000 HYBRID is not designed to work in parallel connection. Please do NOT connect the AC output terminal of more than one POWERWALKER INVERTER 5000 HYBRID in parallel.

## 2.6 Commissioning



### **WARNING!**

Before performing the commissioning, please make sure all the circuit breakers for battery bank, DC input power (PV), AC input power (AC grid) and AC output power (AC loads) are all switched off.

EN

1. Connect battery bank (please refer to Section 2.3) and switch on the circuit breaker for battery bank.
2. Switch the Power Switch to “ON” position. The LCD of upper control panel will be turned on.
3. Press CONFIG button  and configure the POWERWALKER INVERTER 5000 HYBRID as shown in Section 3.4.
4. Switch the Power Switch to “OFF” position.
5. Connect the DC input cables, AC input cables and AC output cables.
6. Switch on the circuit breakers for DC input power, AC input power and AC output power.
7. Switch the Power Switch to “ON” position.
8. Both upper and lower LCD will be turned on (DC input voltage shall be greater than 160V).
9. “LINE Mode” will be shown on in the upper LCD.
10. The lower LCD will show “Waiting” first and then the DC input power “Pdc=xxW”.
11. If no fault trips, the commissioning is successfully completed.

### 3. OPERATION

#### 3.1 Operation Modes

EN

POWERWALKER INVERTER 5000 HYBRID can automatically enter 9 different operation modes depending on the status of DC input power (PV) and AC input power. Please refer to the following table for the 8 operation modes and their corresponding conditions.

	Strong PV Power	Less PV Power	No PV Power	
AC Input Power Present	<b>LINE-PV</b> or <b>SOLAR-PV</b>	<b>LINE-HYBRID</b> or <b>SOLAR-HYBRID</b>	<b>LINE MODE</b>	
AC Input Power Absent	<b>INV-PV</b>	<b>INV-HYBRID</b>	<b>INV MODE</b>	<b>CHARGE MODE</b>

Operation Modes

#### LINE-PV Mode

AC loads are supplied by AC grid (or AC generator), and DC input power (PV) is strong enough to charge battery bank without consuming AC power.

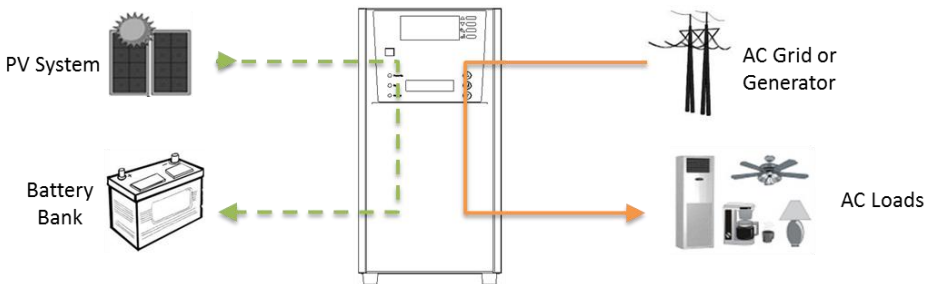



### LINE-HYBRID Mode

AC loads are supplied by AC grid (or AC generator). The power used to charge battery bank firstly comes from PV system and the rest comes from AC grid (or AC generator).

EN

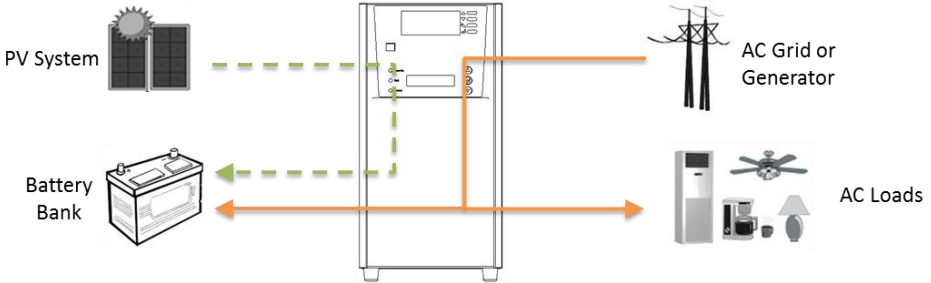

### LINE MODE

As DC input power is too low, AC grid (or AC generator) not only supplies AC loads but also charges battery bank.

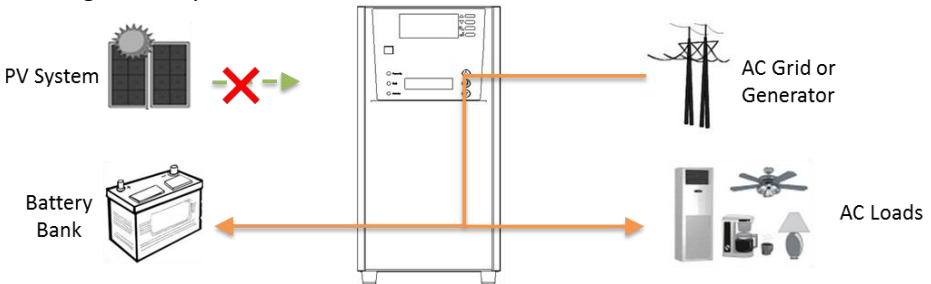

### INV-PV Mode (Inverter-PV Mode)

AC loads are supplied by PV system as backup power without consuming the power from battery bank, and surplus PV power will charge the battery.

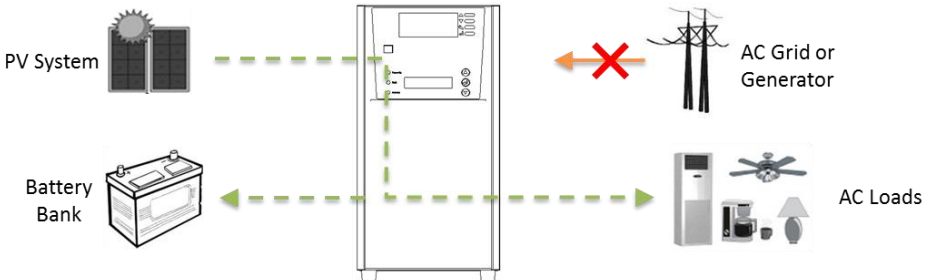

### INV-HYBRID Mode (Inverter-Hybrid Mode)

AC loads are supplied firstly by PV system and the rest by battery bank. The power from PV system helps to prolong the backup time.

EN

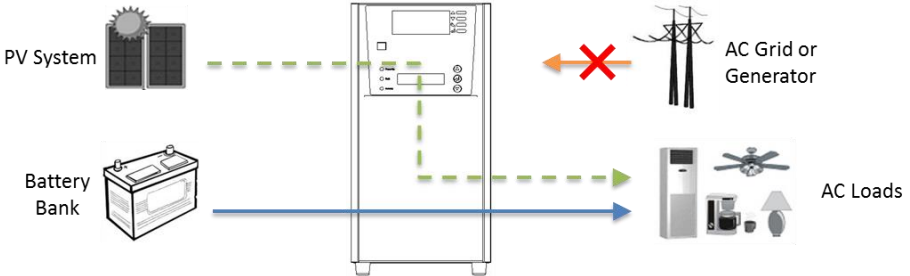

### INV Mode (Inverter Mode)

AC loads are supplied only by the battery bank.

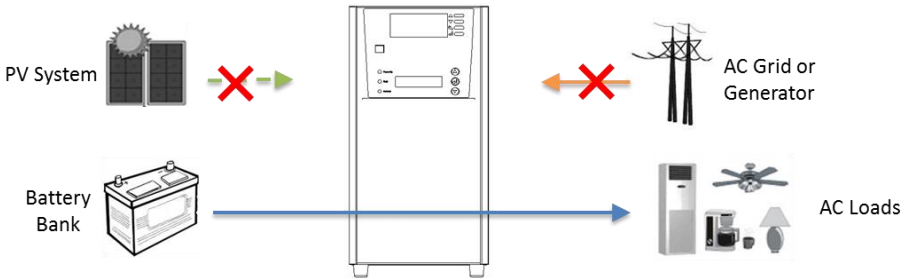

### CHARGE Mode (Charging Mode)

When AC grid is not available, PV system can take over to charge the battery as long as no AC load is connected.

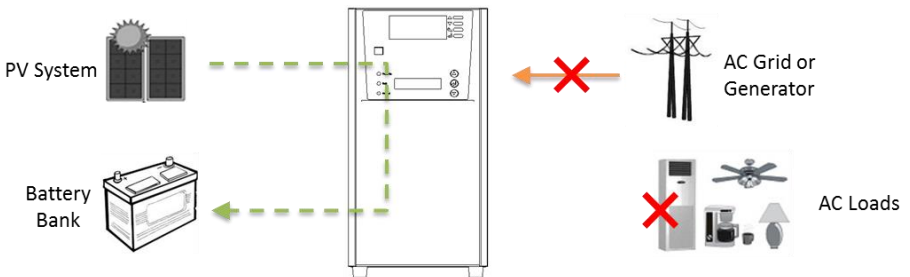

## 3.2 Solar Mode

SOLAR MODE is a special mode which can be enabled via lower control panel (please refer to Section 3.5) SOLAR MODE allows the AC loads to better utilize the power from PV system and consume less power from AC grid (or AC generator) during the LINE MODE. After enabling SOLAR MODE, POWERWALKER INVERTER 5000 HYBRID will automatically enter into SOLAR MODE when the PV power is strong and battery bank is charged to >90% capacity (as shown in the diagram below).

EN

### SOLAR-PV Model

When DC power is strong, AC loads are supplied only by PV system without consuming power from AC grid (or AC generator), and surplus PV power will charge the battery.

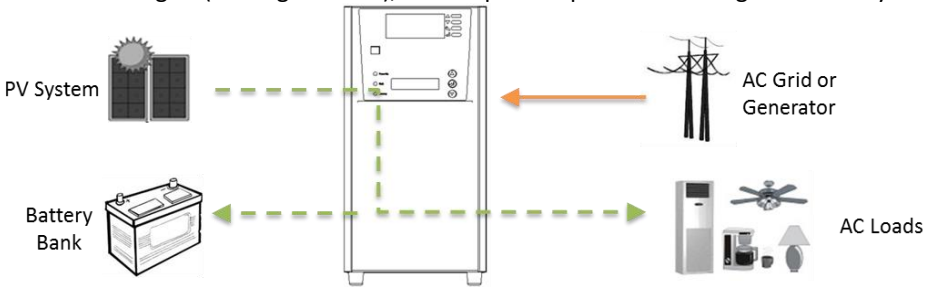

### SOLAR-HYBRID Model

When DC power is less strong, AC loads are supplied by both PV system and battery bank without consuming power from AC grid (or AC generator).

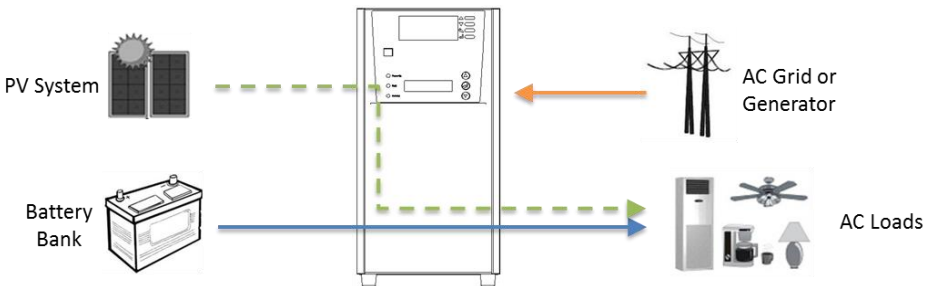

When the PV power is low or battery bank is discharged to <60%, POWERWALKER INVERTER 5000 HYBRID will leave Solar Mode.

### 3.3 Saver Mode

SAVER MODE is a power-saving mode which can be enabled by via upper control panel (please refer to Section 3.4). SAVER MODE allows the product to operate with less power consumption (tare loss) under light-loaded condition.

EN

### 3.4 Configuration via Upper Control Panel

Configuration menu can be accessed by pressing the CONFIG button

There are 5 configuration menus which can be switched by pressing CONFIG button : Input Type, Rated Voltage (disabled), Battery Type, Charger Current and Saver Mode. To return to main screen from either of the configuration menu, press ENTER button .

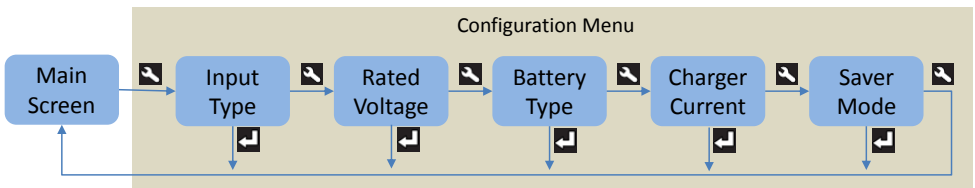

- (1) Input Type: select the type of AC input source, including
  - NORMAL**: input power comes from AC grid
  - GENERATOR**: input power comes from AC generator
  - WIDE RANGE**: input power comes from AC power source which is not pure sine wave

In the Input Type menu, the current selection will marked as below and blink:

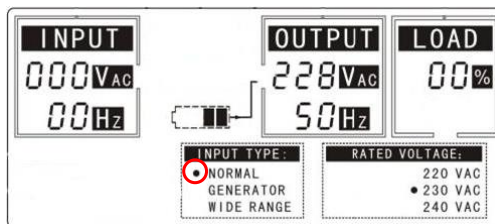

Press ▲ or ▼ to toggle the desired option and press to confirm the setting.

- (2) Rated Voltage: this configuration menu is disabled, and the setting via this menu will not take effect.

(3) Battery Type: select the type of battery bank.

**AGM:** AGM lead acid battery

**GEL:** Gel lead-acid battery

**FLO:** Flooded lead-acid battery

In the Battery Type menu, the current selection will be shown as below.



Press ▲ or ▼ to change the desired option and press  to confirm the setting.

(4) Charger Current: select the output current for battery charger. Options include **35A** and **20A**. The selection of charger current is subject to the battery bank used. The recommended charger current should be 0.1~0.3C.

In the Charger Current menu, the current selection will be shown as below.

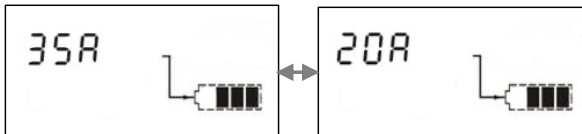

Press ▲ or ▼ to change the desired option and press  to confirm the setting.

(5) Saver Mode: enable or disable the Saver Mode. Options include **ON** and **OFF**.

In the Saver Mode menu, the current selection will be shown as below and blink:



Press ▲ or ▼ to toggle the desired option and press  to confirm the setting.

### 3.5 Configuration via Lower LCD (Solar Mode Setting)

User may set the Solar Mode via lower LCD. The steps are as follows,

1. Press ▲ or ▼ to scroll the page to “Set Solar Mode” menu as shown below.

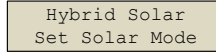

2. Hold **Enter** key to enter the setting page and current setting (ON/OFF) will be shown.
3. Press ▲ or ▼ to switch the between option “ON” and “OFF”.



4. Press **Enter** key and hold for 5 seconds to confirm the setting.

### 3.6 Fault Events

When faults concerning the AC input, AC output and battery bank are tripped, the Fault symbol will be shown on the upper LCD with specified Fault Code. Depending on the fault type, audible alarm might be activated. Please refer to Section 5 for the definition of Fault Code and recommended remedial actions.

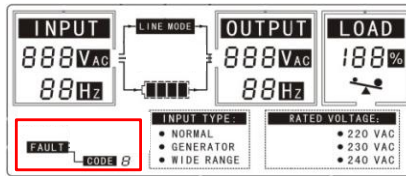

When faults concerning the input from PV system are tripped, the fault will be shown on lower LCD with the Fault LED will be on. Please refer to Section 5 for the definition of Fault Message and recommended remedial actions.

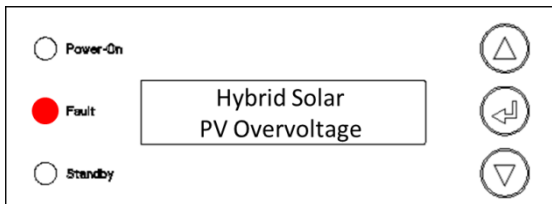

## 4. SPECIFICATION

EN

DC Input (PV Tracker)	
Max. Input DC Power	4500W
Initial Feed-in Voltage	160Vdc
Working Voltage Range	130 ~ 300Vdc
Full Rating Voltage Range	185 ~ 300Vdc
Max. DC Current	24.3A
Max. DC Short-circuit Current	30.4A

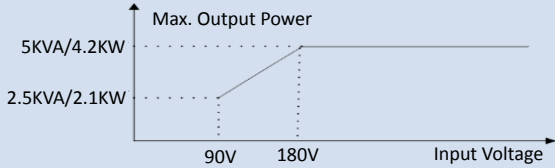
AC Input / Output (Line Mode)	
Input Voltage Waveform	Sinusoidal (utility or generator)
Nominal Input Voltage	230Vac
Low Line Disconnect	170Vac±4% (normal range) 90Vac±4% (generator / wide range)
Low Line Re-connect	180Vac±4% (Normal) 100Vac±4% (generator / wide range)
High Line Disconnect	280Vac±4%
High Line Re-connect	270Vac±4%
Max AC Input Voltage	300Vac rms
Nominal Input Frequency	50Hz / 60Hz (auto detection)
Low Line Frequency Disconnect	40±1Hz
Low Line Frequency Re-connect	42±1Hz
High Line Frequency Disconnect	65±1Hz
High Line Frequency Re-connect	63±1Hz
Output Voltage Waveform	As same as input waveform
Output Short-Circuit Protection	Circuit Breaker 40A
Efficiency (Line Mode)	>95% ( Rated R load, battery full-charged )
Transfer Switch Rating	40A
Transfer Time (AC to DC)	10ms (typical) 15ms max(Normal range setting) 20ms (typical) 40ms max(generator/wide range setting)
Transfer Time (DC to AC)	10ms (typical) 15ms max(Normal range setting) 20ms (typical) 40ms max(generator/wide range setting)
Output Power Limitation	 <p>Max. Output Power</p> <p>5KVA/4.2KW</p> <p>2.5KVA/2.1KW</p> <p>90V 180V Input Voltage</p>

### AC Output (Inverter Mode)

Output Voltage Waveform	Pure Sine Wave
Nominal Output Power	5000VA
Power Factor	0.84
Nominal Output Voltage	230Vac
Output Frequency	50Hz / 60Hz $\pm$ 1Hz (automatic detection)
Output Voltage Regulation	$\pm$ 10% rms
Max. Efficiency (DC to AC)	>95%
Over-Loading Protection	fault after 5s@ $\geq$ 150% load fault after 10s@110%~150% load
Surge Rating	10,000VA
Electric Motor Start-up Capability	2.5HP
Output Short-Circuit Protection	Current limit (Fault after max. 4 cycles)
Rating of Bypass Circuit Breaker	40A
Nominal DC Input Voltage	48V
Min DC Start-up voltage	40V
Low DC Alarm	42.0 $\pm$ 1.2Vdc
Low DC Alarm Recovery	43.2 $\pm$ 1.2Vdc
Low DC Shut-down	40.0 $\pm$ 1.2Vdc
Low DC Shut-down Recovery *	44.0 $\pm$ 1.2Vdc
High DC Shut-down	60.0 $\pm$ 1.2Vdc
High DC Shut-down Recovery	58.0 $\pm$ 1.2Vdc
Power saver setting	0W (Set saver "OFF" at LCD) 5 $\pm$ 2W enter 10 $\pm$ 5W leave (Set saver "ON" at LCD)
Tare loss(nominal)	Saver OFF:<80W Saver ON:<30W
DC component of output	<100mV
Half-wave load detection	Yes (when unbalanced current >35A)

#### Output Power Limitation

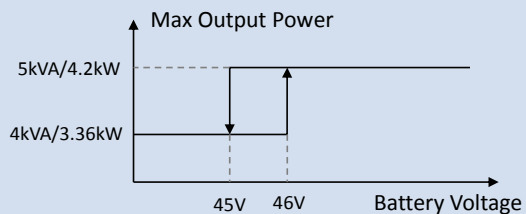

\*Note: Line voltage must be present in order to recover from low DC alarm.



### Battery Charger

Nominal Input Voltage	230Vac
Input Voltage Range	180V~ 270Vac (normal range) 100V~ 270Vac (generator / wide range)
Nominal Output Voltage	Subject to the battery type
Nominal Charge Current	20A (95-175V) for generator / wide range 35A (175-275V) @35A setting 20A (175-275V) @20A setting
Charge Current Tolerance	±10%
Start-up Battery Voltage	>35Vdc
Charger Short-Circuit Protection	Shutdown automatically
Over-Charging Protection	Bat. V ≥60Vdc, Fault, Buzzer alarm
Charge Algorithm	Three charging stages: <b>Boost CC</b> (constant current stage) → <b>Boost CV</b> (constant voltage stage) → <b>Floating</b> (constant voltage stage)

EN

Battery Type Setting (±0.3v/bat)

Battery Type	Boost CC/CV	Float
	Voltage(V)	Voltage(V)
	48	48
Flooded	58.4	53.6
AGM/Gel	56.4	54

Charger current (+/-10%)

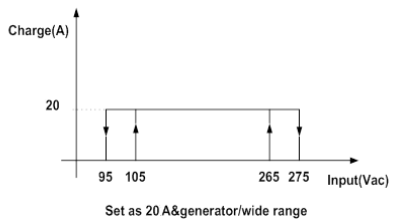
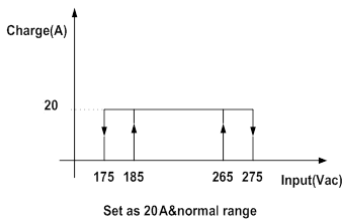
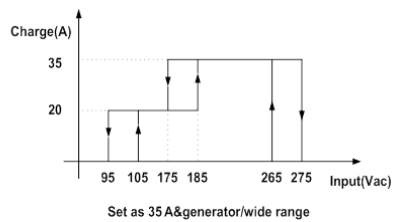
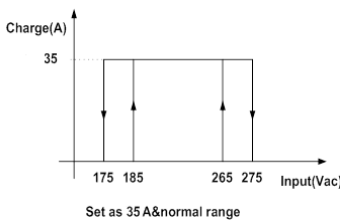

### General Specification

Safety Certification	CE (EN 62109-1/-2)
EMI Classification	IEC 61000-6-4/IEC 61000-6-2
Protection Degree	IP20
Operating Temperature Range	0°C to 45°C
Storage Temperature	-15°C ~ 60°C
Altitude	Elevation: 0 – 1500 Meters
Relative Humidity	5% to 95% non-condensing
Audible Noise	60dB max
Cooling	Forced air, variable speed fan
Dimension (WxHxD)	192.4 x 370.2 x 456 mm
Net Weight	17.2 kg
Gross Weight	20.3 kg
Input DC Connector	MC4
DC Output Wiring Gauge	4AWG or larger+M8
AC Input/Output Wring Gauge	L/N: ≥10AWG, G: larger than L/N's gauge

## 5. TROUBLESHOOTING

The explanation of Fault Code shown on the upper LCD can be found in the table below,

Fault Code	Description	Trigger Condition	Warning (with output)	Fault (no output)	Resumption	
					Auto/Manual	Condition
--	Low DC Voltage Alarm	DC voltage<Low DC Alarm	1 beep/2s	--	Auto	DC voltage > Low DC Alarm
0	Low DC Voltage Protection	DC Voltage<Low DC Shut-down	--	Constant beep	Auto	DC voltage > Low DC Shut-down
1	Over Charge Protection	DC Voltage>High DC input Shut-down	Constant beep	--	Manual	--
1	Over Voltage Protection	DC Voltage>High DC input Shut-down	--	Constant beep	Auto	DC Voltage<High DC input Shut-down Recovery
2	Over Load Protection	110%~150% load	1 beep/0.5s Constant for 10s	Constant beep	Manual	--
		>150% load	1 beep/0.5s Constant for 5s	Constant beep	Manual	--
3	Output Short-circuit Protection	Output Voltage<20Vrms	--	Constant beep	Manual	--
4	Fan Fault Protection	Fan blocked Fan defective	2 beeps/2s Constant for 1min	Constant beep	Manual	--
5	Over Temp Protection	Heat sink $\geq 100^{\circ}\text{C}$	--	Constant beep	Auto	Heat sink $\leq 55^{\circ}\text{C}$
6	Back-EMF Protection	Input and output reversed	--	Constant beep	Manual	--
9	Output Abnormal	Output Voltage <170Vrms and output current < 32Arms or Output Voltage >280Vrms	--	Constant beep	Manual	--

Problem	Possible Causes	Remedy
<b>No LCD display</b>	1. Battery Weak (<35V )	1. Re-charge the battery
	2. Battery defective (can't be charged)	2. Replace the battery
	3. Power switch is not switched on	3. Switch on the power switch
	4. Battery polarity reversed	4. Sent the unit for repair
<b>AC grid normal but works in inverter mode</b>	1. AC cables fell off	1. Check AC cabling
	2. Input protector tripped	2. Reset the input protector
<b>Alarm buzzer beeps continuously</b>	1. Overloaded	1. Reduce the AC loads
	2. Output short-circuited	2. Disconnect all loads and check the cables again
	3. Over temperature	3. Improve the ventilation of installation location
	4. Over charged	4. Restart the unit
	5. Over voltage	5. Check battery bank voltage
	6. Fan fault	6. Check if the fan is blocked by foreign objects
	7. Back-EMF	7. Check if the AC Input and output cables are reversed
	8. DC voltage under the low DC shut-down	8. Make sure the AC grid is normal to charge the battery
<b>Back-up time is shortened</b>	1. Overload	1. Reduce the AC loads
	2. Battery voltage is too low	2. Charge battery for 8 hours or more
	3. Battery bank is too small	3. Increase battery bank capacity

Error Message on Lower LCD	Possible Causes	Remedy
<b>PV Overvoltage</b>	1. DC Voltage from PV Panel exceeds the upper limit	1. Re-configure the PV panel connection
	2. PV Panel is defective	2. Replace the PV panel
<b>Over Temperature</b>	1. Poor ventilation	1. Improve the installation environment by increasing the air circulation
	2. Hardware damage	2. Send the unit for repair
<b>Internal Fan Lock</b>	1. Fan was blocked by foreign object	1. Remove the object which blocks the fan
	2. Fan detection circuit is malfunctioned	2. Send the unit for repair
<b>EEPROM Failure</b>	Internal memory malfunctioned	Send the unit for repair
<b>High DC Bus</b>	Internal DC bus voltage is high	Send the unit for repair
<b>Low DC Bus</b>	Internal DC bus voltage is low	Send the unit for repair

## 6. DISPOSAL

In the event the product reaches the end of its service life, please contact the local dealer for disposal instructions.

EN



**The product must not be disposed of with the household waste.**

Disposal of the product at the end of its service life shall be done in accordance with applicable disposal regulations for electronic waste.